

DENSITÉ 3+ XIP-3901-UC

Dual-channel 12G/Quad Link 3G/3G/HD-SDI Upconverter with HDR Application for XIP-3911 and XIP-3901



XIP-3901-UC application for the reprogrammable software-defined platforms Densité 3+ XIP-3911 and XIP-3901.

The XIP-3901-UC application from Grass Valley is a dual-channel 12G/quad link 3G/3G/HD-SDI upconverter, which is designed to synchronize, upconvert and process HD and 3G 1080p signals for both 1080p and 4K UHD 2160p broadcast production. The XIP-3901-UC application features broadcast-quality scalers, pixel-based de-interlacing and advanced motion adaptive de-interlacing and anti-ringing, detail enhancement. The XIP-3901-UC application will delay 12G/3G/HD embedded audio and metadata to maintain synchronization with video.

The optional HDR processor, XIP-3901-UDC-HDR, allows conversion between SDR and HDR formats and wide color gamut BT.709 and BT.2020, supporting HLG (ITU-R BT.2100), PQ (ITU-R BT.2100), and S-Log3/S-Gamut3 formats. In addition to

the Grass Valley LUTs, you can select BBC LUTs v1.4 or you can choose your own custom LUTs compliant to Adobe cube file v1.0 for fully flexible HDR processing. The HDR processor operates in full 10-bit video signals with the ability to pass sub-blacks and super-whites in SMPTE Narrow video signals and the support of SMPTE Full in PQ and S-Log3 signals.

The XIP-3911 and XIP-3901 agile processing platforms come with all the 12G/quad link 3G/3G/HD-SDI connectivity to support two 4K UHD processing paths. The XIP-3911 and XIP-3901 are installed in the established Densité modular frame. Due to advanced processing capabilities and power requirements, the XIP-3911 and XIP-3901 are supported by the Densité 3+ FR1 and FR4 frames.

Based on the proven Densité modular framework of over 100 cards, the flexible, space-efficient XIP-3911 and XIP-3901 agile processing platforms can accommodate a gradual adoption of different production elements into 1080p and 4K UHD broadcasting workflows – and enables dual HDR/SDR production – all while protecting your investment in installed equipment. With flexibility to configure up to 12 XIP-3911 dual-channel processing applications per Densité 3+ FR4 frame, the Densité platform scales to a market-leading density of 24 4K UHD processors with HDR conversions in a 4 RU frame. This means space and cost-efficient scaling today and tomorrow. The XIP-3901-UC-IP is configured, controlled and monitored by GV Orbit from Grass Valley.

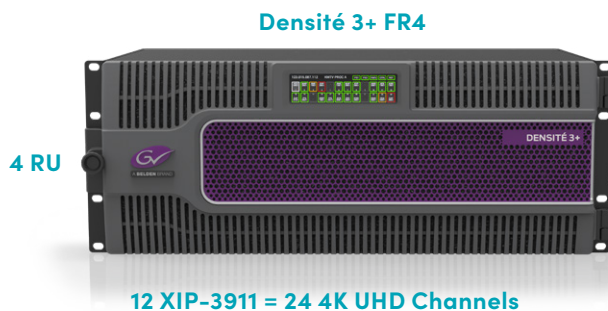

Key Features

- Independent dual processing channels
- HD 720p/1080i and 3G 1080p inputs
- 3G 1080p, quad link 3G and 12G 2160p outputs
- 12G-SDI Mode 1 and Type 1
- Quad link 3G in 2SI and square division
- 3G level A & level B dual link
- High-quality scaler and advanced de-interlacer
- Integrated frame synchronizer (freeze to last valid frame on error)
- Audio/video deglitcher to handle video hot switch at the input
- XIP-3901-UDC-HDR option provides HDR conversion supporting both Wide Color Gamut BT.709/ BT.2020 and High Dynamic Range: HLG, PQ and S-Log3:
 - All processing operates in full 10-bit video signals with ability to pass sub-blacks and super-whites in SMPTE narrow video
 - Choice between Grass Valley conversions algorithms, BBC HLG LUT v1.4 and user defined 3D-LUT support
 - ITU R BT 2111 HLG/PQ color bar test patterns
- External reference or URS frame reference
- Embedded audio and metadata delay and synchronization
- GV Orbit for configuration, control and monitoring
- Individual XIP-3911 and XIP-3901 applications licensed, purchased as needed
- Rapid switching between applications

XIP-3901-UDC-HDR processing option supported conversions:

GV LUT Conversions	BBC LUTs v1.4	Up to 8 User-defined LUTs
BT.709↔BT.2020	BT.709↔HLG BT.2100 Scene-referred	Adobe cube file v1.0 – 33 cube
BT.709↔HLG BT.2100	BT.709↔HLG BT.2100 Display-referred	BT.709↔BT.2020
BT.709↔PQ ST.2100	HLG BT.2100↔PQ BT.2100	Narrow↔Full range
S-Log3/S-Gamut3→ BT.709	S-Log3 BT.2020→HLG BT.2100	
S-Log3/S-Gamut3→HLG BT.2100		
S-Log3/S-Gamut3→PQ BT.2100		

And new ITU R BT.2111 HLG/PQ Color bar test patterns

Supported input/output video formats:

Input Format	Output Format									
	1080p50 A	1080p59 A	1080p50 B DL	1080p59.94 B DL	2160p50 Mode 1	2160p59.94 Mode 1	Quad Link 3G 50 A	Quad Link 3G 59.95 A	Quad Link 3G 50 B DL	Quad Link 3G 59.94 B DL
720p50	●	●	●	●	●	●	●	●	●	●
720p59.94	●	●	●	●	●	●	●	●	●	●
1080i50	●	●	●	●	●	●	●	●	●	●
1080i59.94	●	●	●	●	●	●	●	●	●	●
1080p50 A	●	●	●	●	●	●	●	●	●	●
1080p59.94 A	●	●	●	●	●	●	●	●	●	●
1080p50 B DL	●	●	●	●	●	●	●	●	●	●
1080p59.94 B DL	●	●	●	●	●	●	●	●	●	●

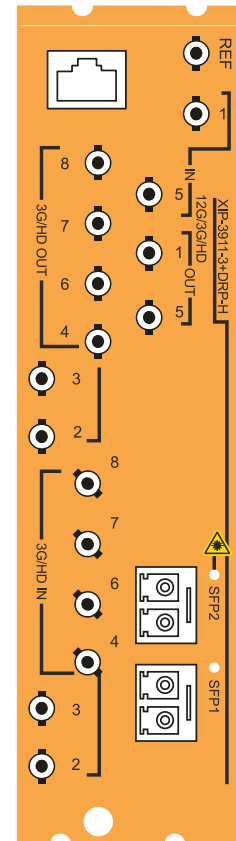

XIP-3911-3+DRP-H

Specifications

SDI (Inputs/Outputs)

Physical: 16 HD-BNC connectors: 2 in, 8 out

SDI Standard:

- SMPTE ST 292 (1.485, 1.485/1.001 Gb/s)
- SMPTE ST 424 (2.970, 2.970/1.001 Gb/s)
- SMPTE ST 2082-1:2015 (out 1 & 5)

Supported Input Formats:

- HD: SMPTE ST 274: 1080i59.94, 1080i50
- HD: SMPTE ST 296: 720p59.94, 720p50
- 3G: SMPTE ST 425 level A (mapping 1), level B dual link: 1080p59.94, 1080p50

Supported Output Formats:

- 3G: SMPTE ST 425 level A (mapping 1), level B dual link: 1080p59.94, 1080p50
- 4K UHD: Quad Link 3 Gb/s SMPTE ST 425-5: 1080p59.94, 1080p50
- 12G: SMPTE ST 2082-10: 2160p59.94, 2160p50

Cable length (Belden 1694A):

- HD: 250m (820 ft.) at 1.485 Gb/s
- 3G: 150m (492 ft.) at 2.970 Gb/s
- 12G: 55m (180 ft.) at 11.88 Gb/s

Jitter:

- HD/SD: <0.2 UI (alignment jitter)
- 3G: <0.3 UI (alignment jitter)
- 12G: <0.3 UI (alignment jitter)

Reference Input

Physical: SMPTE ST 170/SMPTE ST 318/ITU 624-4 blackburst

Ethernet Port for Media

Not used by this application

Ethernet Port for Control

Physical: One electrical RJ45 port

Standard: IEEE 802.3 1000 Mb/s

Video Processing Performance

Signal path: 10 bits minimum

Electrical

Power: 60W maximum

Ordering

Application Software

XIP-3901-UC

12G/3G/HD SDI Dual Up Converter application

Application Option

XIP-3901-UDC-HDR

HDR processing option

Densité 3+ Frame

XIP-3911

Agile SDI/IP processing platform

XIP-3911-3+DRP-H

Double rear panel for Densité 3+ with HD-BNC

Remote Control

GV Orbit version 1.2, iControl or iControl Solo (version 7.50 or higher required)

XIP-3901-UC Application Functional Diagram

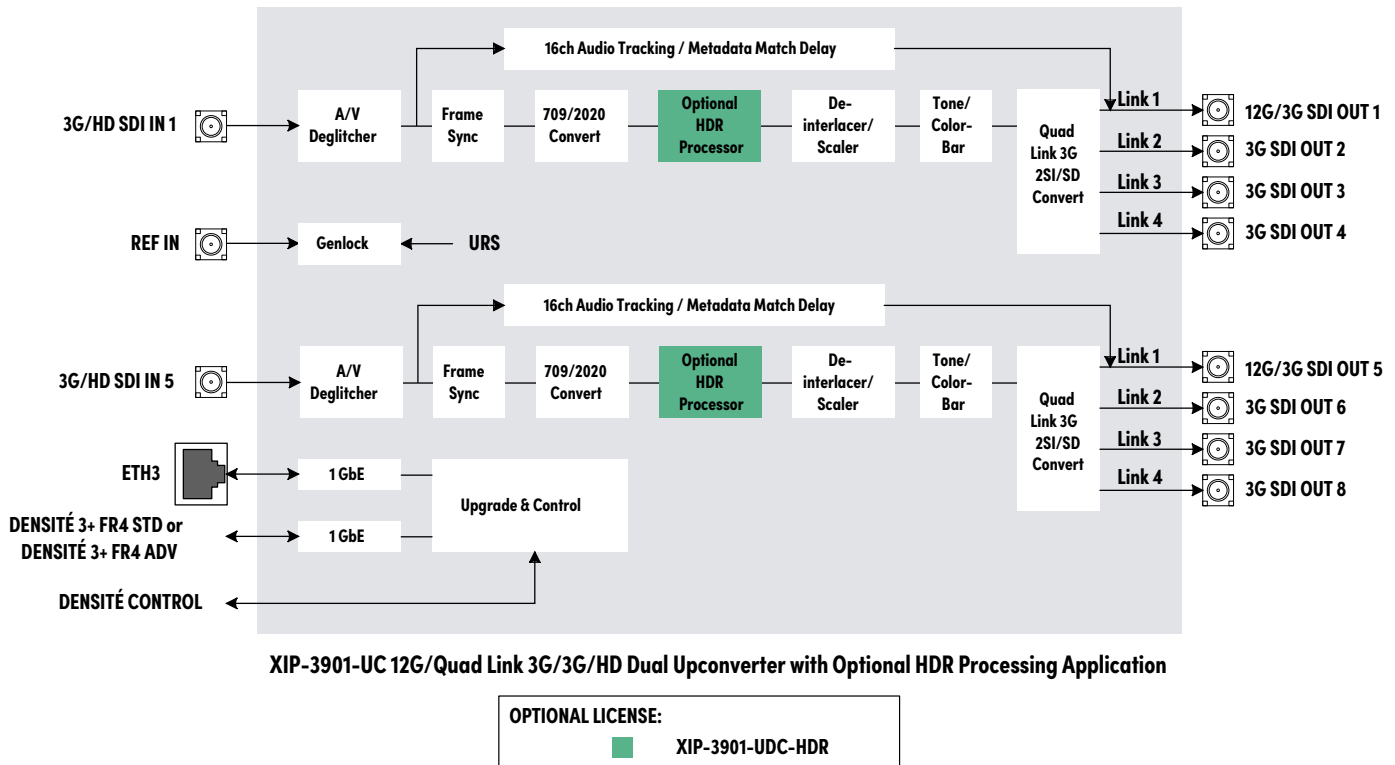

XIP Application Portfolio

All the processing applications delivered on the XIP-3911 and XIP-3901 platforms allow live productions, either from trucks, venues, stadiums or broadcast facilities to make the most of new UHD and HDR formats. Packing lots of audio/video processing power in a small form factor results in savings in terms of space, power and weight.

The XIP-3911 Agile Processing Platform also provides long-term value by protecting a customer's CAPEX investment in current HD and UHD SDI and now IP infrastructure. The application-based licensing model adapts the XIP-3911 to new workflows with different software applications resulting in a truly virtualized hardware environment.

XIP Application Agility Evolution

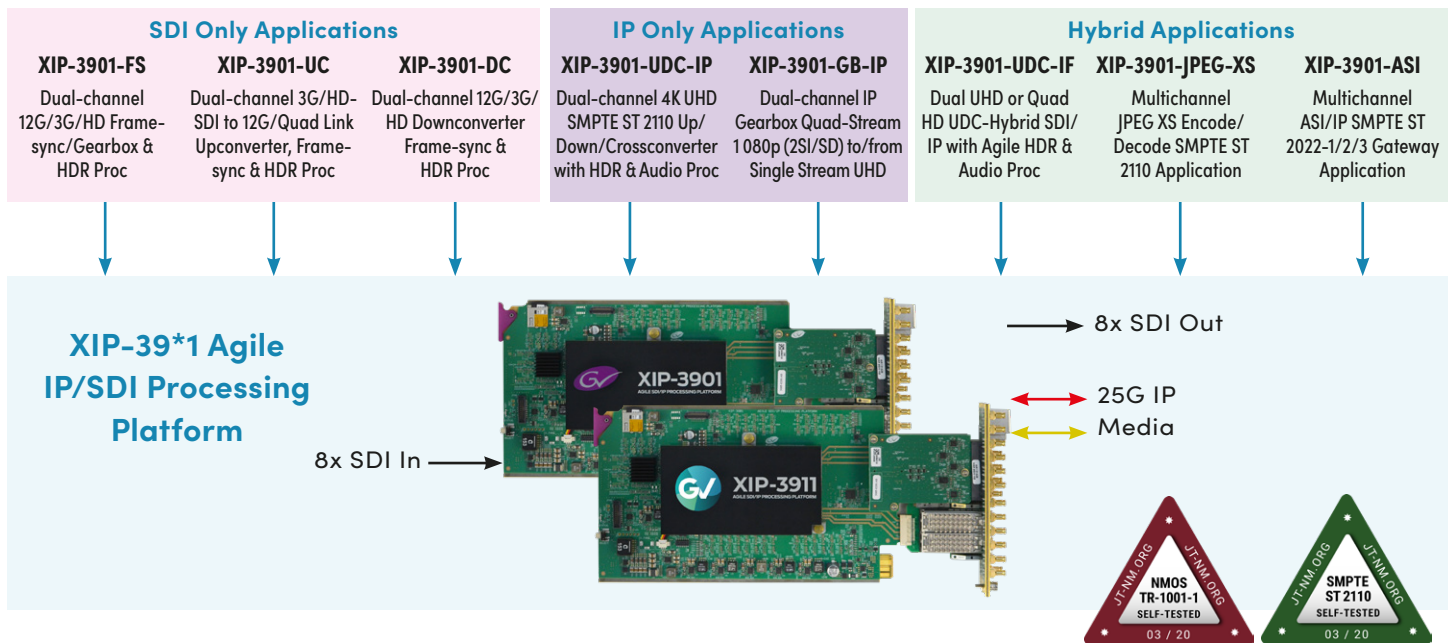

This product may be protected by one or more patents. For further information, please visit: www.grassvalley.com/patents

DS-PUB-3-0948A-EN

Grass Valley®, GV® and the Grass Valley logo are trademarks or registered trademarks of Grass Valley USA, LLC, or its affiliated companies in the United States and other jurisdictions. Grass Valley products listed above are trademarks or registered trademarks of Grass Valley USA, LLC or its affiliated companies, and other parties may also have trademark rights in other terms used herein. Copyright © 2020-2022 Grass Valley Canada. All rights reserved. Specifications subject to change without notice.

www.grassvalley.com Join the Conversation at GrassValleyLive on [Facebook](#), [Twitter](#), [YouTube](#) and Grass Valley on [LinkedIn](#)