



LC350

Single-channel Motion Adaptive Standards Converter

LC350 is a highly cost-effective, linear motion adaptive standards converter for many applications.

LC350 single channel linear frame-rate converters from Grass Valley® offer legendary motion-adaptive conversion quality at a very affordable price.

The LC350 is ideal for a wide range of applications, including high-density international program distribution and backup channels. Its low price point also brings the LC350 within reach of AV prosumer, college and house of worship

users, delivering conversion quality and feature levels previously only achievable with significantly more expensive technology.

Features of the LC350 include: linear motion-adaptive frame-rate conversion, up, down and cross format conversion, frame synchronization, 16-channel embedded audio processing, closed-caption/timecode handling, preset/signaling ARC modes, dual PSUs and continuous

output when input switches. The LC350 also offers easy control direct from its front panel as well as remote control via GV Orbit®.

The LC350 also includes analog composite CVBS and component Y/C I/O, balanced and unbalanced AES I/O, along with analog audio I/O – ideal for local commentary insertion or monitoring.

LC350 Front Panel

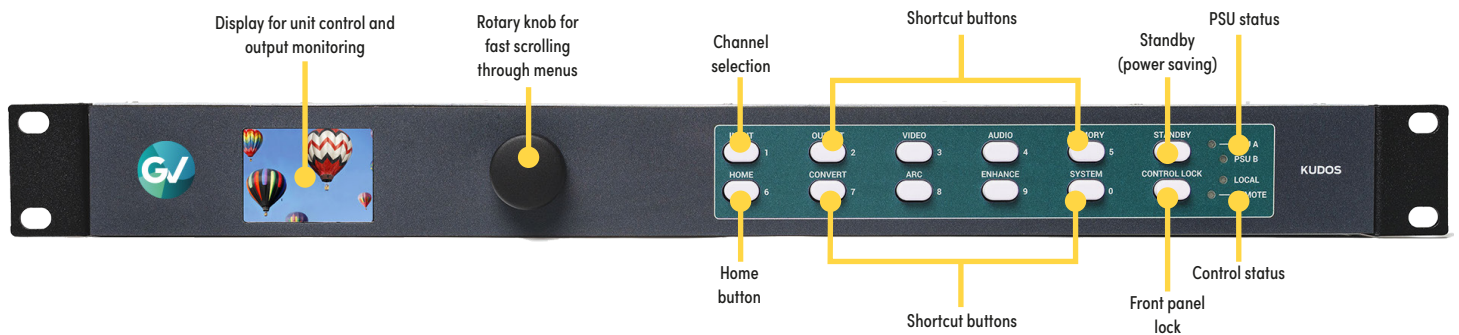

Key Features

- Linear motion-adaptive CVBS/YC and SD/HD/3G-SDI frame-rate conversion
- CVBS/YC and SD/HD/3G-SDI up, down and cross conversion
- Synchronization, legalization and color correction
- 16-channel embedded audio processing for each video channel
- Balanced and unbalanced AES, and analog audio I/O
- Continuous output when input standard switches
- Closed caption, WST and timecode handling
- Automatic aspect ratio conversion (AFD, VI, L23) with user line choice for SMPTE ST 2016
- Logo inserter, sidebar keyer and noise reduction
- Powerful picture enhancement tools and clean cut mode
- Support for fiber input and output
- Dual PSU as standard
- Front panel and remote control via GV Orbit
- Front panel control lock
- GPI/O support
- SMPTE ST 2020 metadata support

Applications

- Fast news integration – any frame rate, any format
- Corporate AV – international business conferences
- Campus TV – educational and informational
- House of worship – management of multiple different sources

LC350 Rear Panel

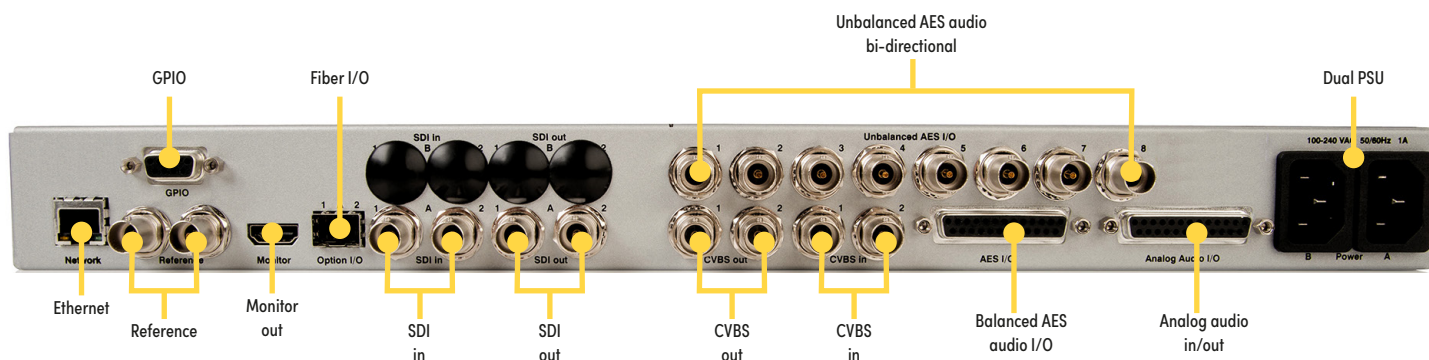

Specifications

Signal Inputs

Serial digital 2x 75Ω SD/HD/3G serial digital with embedded audio

Input standards:

- 3 Gb/s HD-SDI, SMPTE ST 425 level A, dual-link level B
- 1.5 Gb/s HD-SDI SMPTE ST 292/SMPTE ST 299
- 270 Mb/s SD-SDI SMPTE ST 259

Composite PAL, NTSC, NTSC-J, PAL-M, PAL-N, N4.4, SECAM

12-bit ADCs

Analog component YC

Reference: 1x loop-through HDTV Trisync/SD Bi-sync (black & burst) SMPTE ST 240/SMPTE ST 274

Audio AES:

- Up to 8x balanced AES inputs – via 25-way D-Type
- Up to 8x unbalanced AES inputs – via 8x BNC

Analog audio: 2x stereo analog inputs via 25-way D-Type

Signal Outputs

Serial digital 2x 75Ω SD/HD/3G serial digital with embedded audio

Output standards:

- 3 Gb/s HD-SDI, SMPTE ST 425 level A, dual-link level B
- 1.5 Gb/s HD-SDI SMPTE ST 292/SMPTE ST 299
- 270 Mb/s SD-SDI SMPTE ST 259

Composite PAL, NTSC, NTSC-J, PAL-M, PAL-N 1 2-bit DACs

Audio AES:

- Up to 8x balanced AES outputs – via 25-way D-Type
- Up to 8x unbalanced AES outputs – via 8x BNC

Analog audio: 2x stereo analog outputs via 25-way D-Type

Input Standards

(auto detect) 525, 625

720 50/59.94/60p

1080 50/59.94/60i

1080 50/59.94/60p (Levels A and B)

720/1080 23/24/25/29/30p

1080 23/24/25/29psf, with film detection and processing

Output Standards

525, 625

720 50/59.94/60p

1080 50/59.94/60i

1080 50/59.94/60p (Levels A and B)

720/1080 23/24/25/29/30p

1080 23/24/25/29psf, with film detection and processing

Conversion Functions

Modes: Linear Standards Conversion

Upconversion, Downconversion, Crossconversion

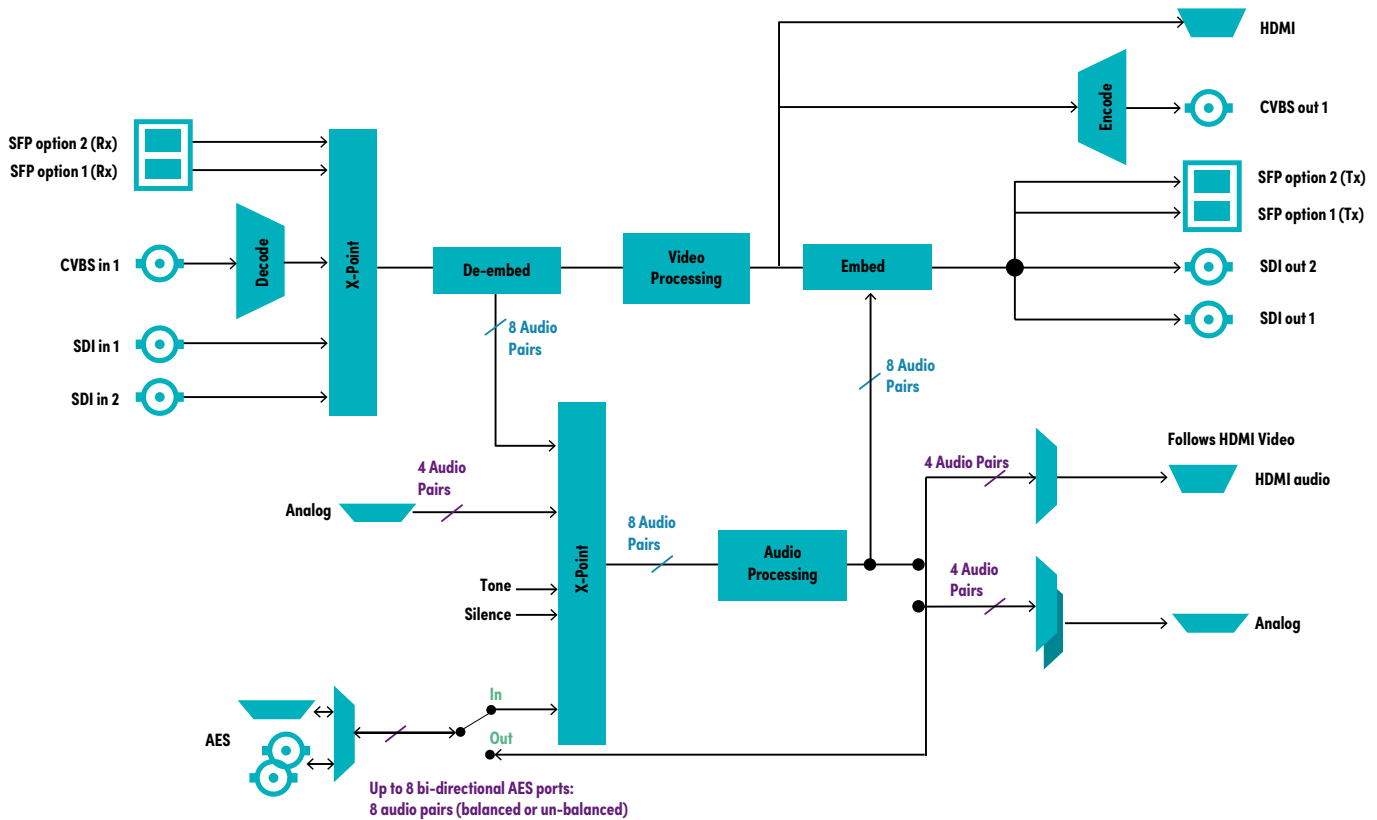

Specifications (cont.)

Manual or Automatic ARC

AFD (SMPTE ST 2016), VI (RP186), WSS (L23)

SD input format: Normal 4:3, Anamorphic 16:9, Letterbox 14:9, Letterbox 16:9

SD output format: Normal 4:3, Anamorphic 16:9, Letterbox 14:9, Letterbox 16:9

Auto zoom: On/Off

Manual zoom: Zoom $\pm 20\%$

Safe area marker: Off, 16:9, 4:3

Manual controls: size, aspect, pan, tilt Wide range of ARC presets including 702 sample line mode

ARC specific memories: 32 user-configurable presets for ARC only controls

Audio Functions

Analog audio:

- Two pairs of analog inputs and two pairs of analog output are available individually to the processing channel
- Headroom +24 dBu; balanced connection

AES audio:

- AES audio is accessible via 8 bidirectional ports which can be configured as inputs or outputs
- AES input is auto-detected as PCM (32-96 kHz) or non-PCM (48 kHz locked to relevant video input)

Embedded audio:

- 16-channel embedded audio processing
- PCM audio processing includes channel level gain and delay compensation, as well as channel level routing/shuffle with audio phase inversion
- Non-PCM processing features pair level routing and delay compensation

Metadata

Closed caption CEA608 <> CEA708

Timecode conversions

WST/SMPTE RDD08/SMPTE ST 2031 conversion

SMPTE ST 2020 embed/de-embed

Enhancement

To control aliasing in down conversion and to add a subjective impression of sharpness in upconversion

Vertical enhancement:

- The V Enhance function enables controlled attenuation and gain to be applied to the chosen vertical frequency bands
- Frequency band selection (Low, Med, High) with 5 preset enhancement levels (Soft 2, Soft 1, Normal, Sharp 1, Sharp 2)

Horizontal enhancement:

- The H Enhance function enables controlled gain to be applied to the chosen horizontal frequency bands
- Frequency band selection (Med, High), with 5 preset enhancement levels 0-4

Horizontal filter:

- H filter frequency determines the frequency band in which the H filter shape function is applied
 - 5 preset levels (Low 2, Low 1, Normal, High 1, High 2)
- H filter Shape determines the sharpness of the output by changing the rate of anti-alias filter cut-off in horizontal frequencies
 - 5 preset levels (Soft 2, Soft 1, Normal, Sharp 1, Sharp 2)

Noise reduction: Spatial, Recursive Y/C alignment – Corrects for up-stream luma chroma displacement

System

Pattern Off, Black, Ramp, Bars

Proc amp:

- Black Level: +100 to -100 mV (0) in 0.8 mV steps
- Contrast: -6 dB to +6 dB (0) in 0.2 dB steps
- Saturation: -6 dB to +6 dB (0) in 0.2 dB steps
- Y Gamma: 0.4 to 1.7 (1) in 0.1 steps

Color correction:

- Red, Green, Blue Lift: +200 to -200 mV (0) in 0.8 mV steps
- Red, Green, Blue Gain: -6 dB to +6 dB (0) in 0.2 dB steps
- Red, Green, Blue Gamma: 0.4 to 1.7 (1) in 0.1 steps

Specifications (cont.)

Adjustable legalizer: Off, 700 mV, 721 mV, 735 mV, 746 mV

Freeze: On/Off

Genlock: Reference lock, Input lock, Free run

Memories: 16 user memories

EDH support

Communications

Remote control via GV Orbit/RollCall network (IP)

Power (Primary and Secondary)

Input voltage range: 100 – 240 VAC, 50/60 Hz 1.5A (Max) via three-pin IEC power socket

Mechanical

Temperature range: 0 to 45° C (32° to 113° F) operating

Cooling: Internal fan, side venting

Weight: Approximately 2.4 kg (5.3 lbs.)

Case type: 1 RU, rack mounting

Dimensions: 44 x 430 x 170 mm (1.7 x 16.9 x 6.7 in.) (HxWxD)

GPIO: 8 available (4x GPI and 4x GPO)

GPI action: Freeze, Black, Pattern, Video Input

GPO tally: Freeze, Black, Pattern (Ramp), SDI Input 1 OK, SDI Input 2 OK

Throughput Delay

Video processing delay:

field = 16.7 or 20 ms

frame = 33.3 or 40 ms

With scaling active in same frame rate:

Ref lock/Free run – between 3 and 5 fields + ~200 μ s

Input lock (SDI) – 3 fields + 1 ms

With scaling active in 525/59i output:*

Ref lock/Free run – between 2 and 4 fields + ~200 μ s

Input lock (SDI) – 2 fields + 1 ms

With same standard in & out and Sync mode = Enabled:

Ref lock/Free run – between ~200 μ s and 1 frame + ~200 μ s

Input lock (SDI) – ~1 ms

Frame rate conversion:

Any lock mode – 110 ms typical

Audio processing delay: Automatically tracks the video processing delay

*Throughput delay increases with low frame rate (≤ 30 Hz) inputs or outputs

Ordering

6163501

LC350

Single-channel video & audio processing unit, including linear motion-adaptive frame rate/format conversion, frame synchronization, ARC control, CC, WST and timecode handling, picture enhancement tools, video processing controls, legalizer, color correction, noise reduction, side-bar keyer, logo inserter and 16-channel audio processing incl. gain, delay & shuffling. SDI (BNC or Fiber), CVBS/YC, GPI, AES and analog audio I/O. HDMI monitor output & dual PSUs.

This product may be protected by one or more patents. For further information, please visit: www.grassvalley.com/patents

DS-PUB-3-0731C-EN

Grass Valley®, GV®, GV Grass Valley®, and the Grass Valley logo are trademarks or registered trademarks of Grass Valley USA, LLC, or its affiliated companies in the United States and/or other jurisdictions. Grass Valley products listed above are trademarks or registered trademarks of Grass Valley USA, LLC or its affiliated companies, and other parties may also have trademark rights in other terms used herein. Copyright © 2018-2024 Grass Valley Canada. All rights reserved. Specifications subject to change without notice.

www.grassvalley.com Join the Conversation at GrassValleyLive on [Facebook](#), [X](#), [YouTube](#) and Grass Valley on [LinkedIn](#)