



SV2000 & SV4000

Up/down/cross-converters and Frame Sync

SV2000 and SV4000 are cost-effective, high-density up/down/crossconverters able to handle a wide range of video and audio processing and synchronization tasks.

Key Features

- SD/HD/3G up/down/crossconversion
- Independent dual channel (SV2000) and quad channel conversion (SV4000)
- Frame synchronization
- Flexible video and audio I/O configuration
- 16-channel embedded audio processing for each video channel
- Continuous output when input standard switches
- HDMI monitor output
- Dual PSU as standard
- Relay bypass on primary SDI inputs
- Automatic aspect ratio conversion (AFD, VI, L23)
- Powerful picture enhancement tools
- User friendly front panel as well as remote control via GV Orbit
- Closed caption and timecode handling
- User chosen line for SMPTE ST 2016
- GPI support
- Front panel control lock
- Caption generator
- Logo inserter
- Sidebar keyer
- Clean cut
- Composite input/output

Optional Features

- Fiber input/output

Applications

- Integration of SD programming into HD schedules
- Supporting legacy SD channels with HD produced content

SV2000/4000 Front Panel

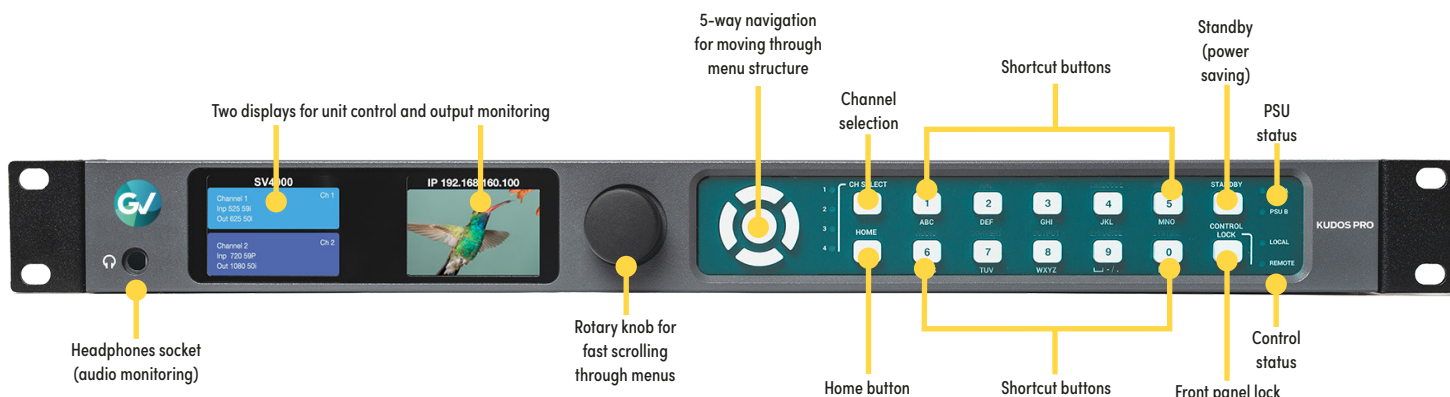

SV2000 Video Processing

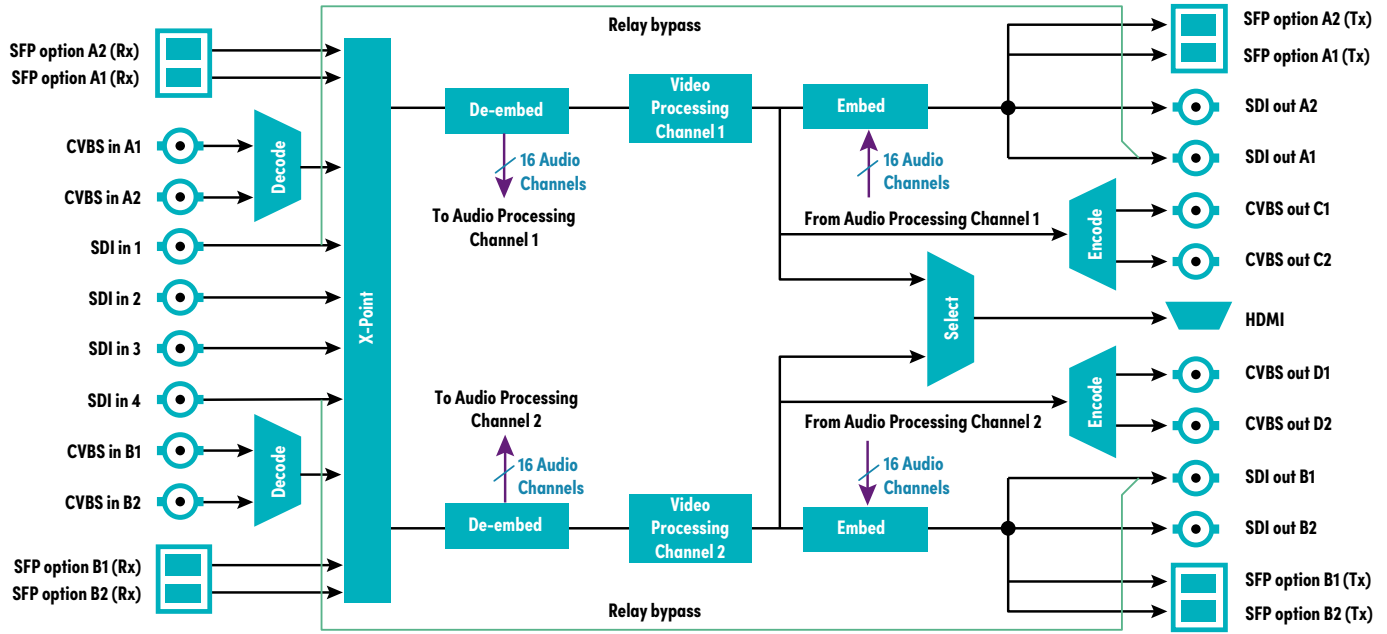

SV2000 Audio Processing

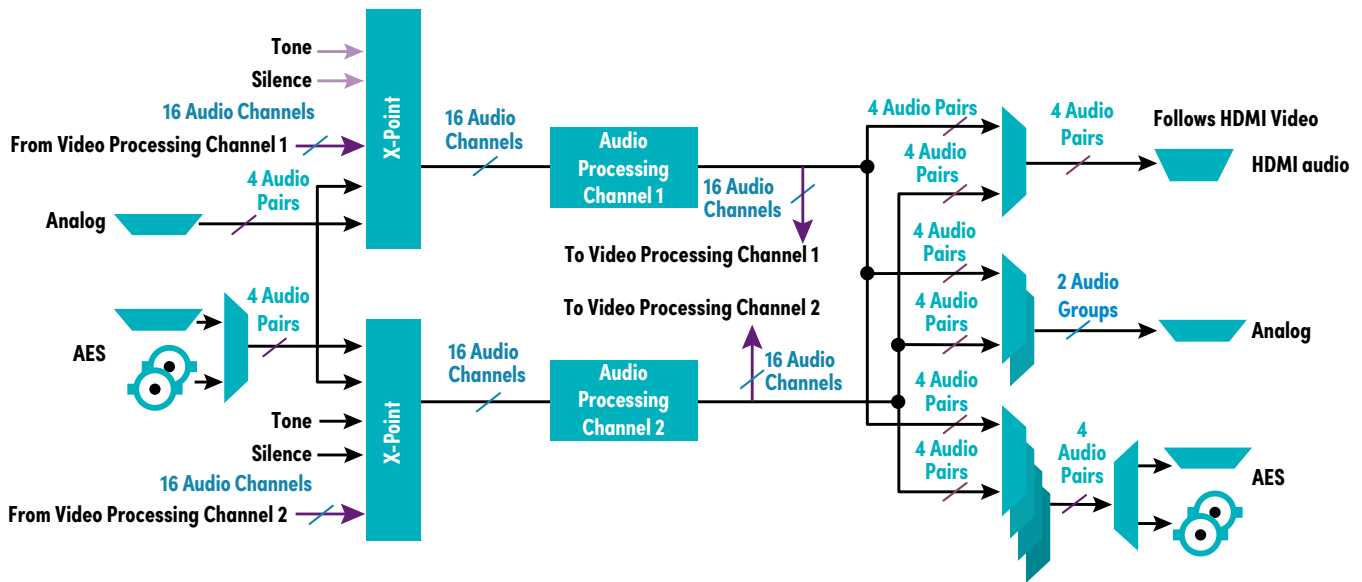

SV4000 Video Processing

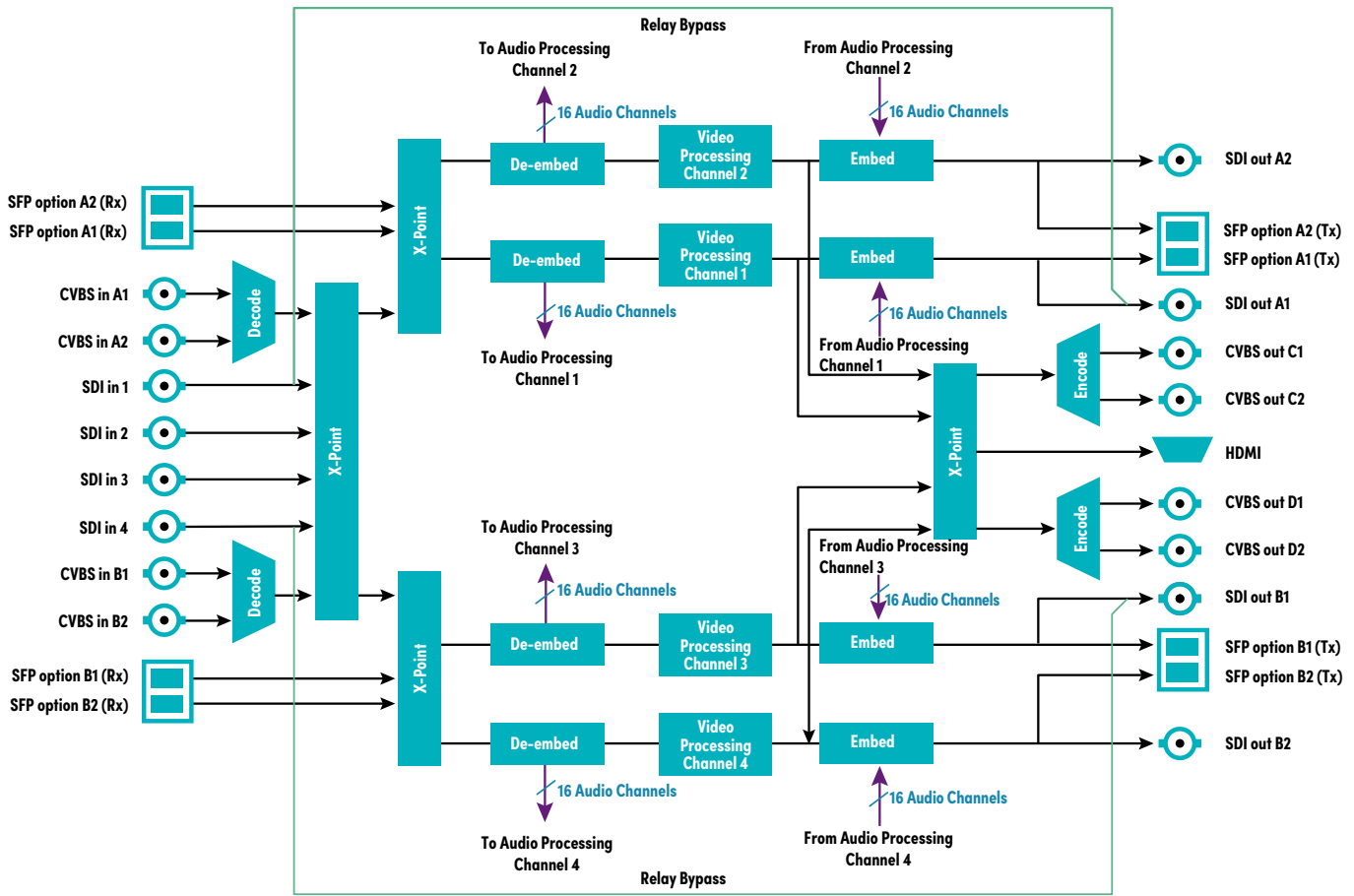

SV4000 Audio Processing

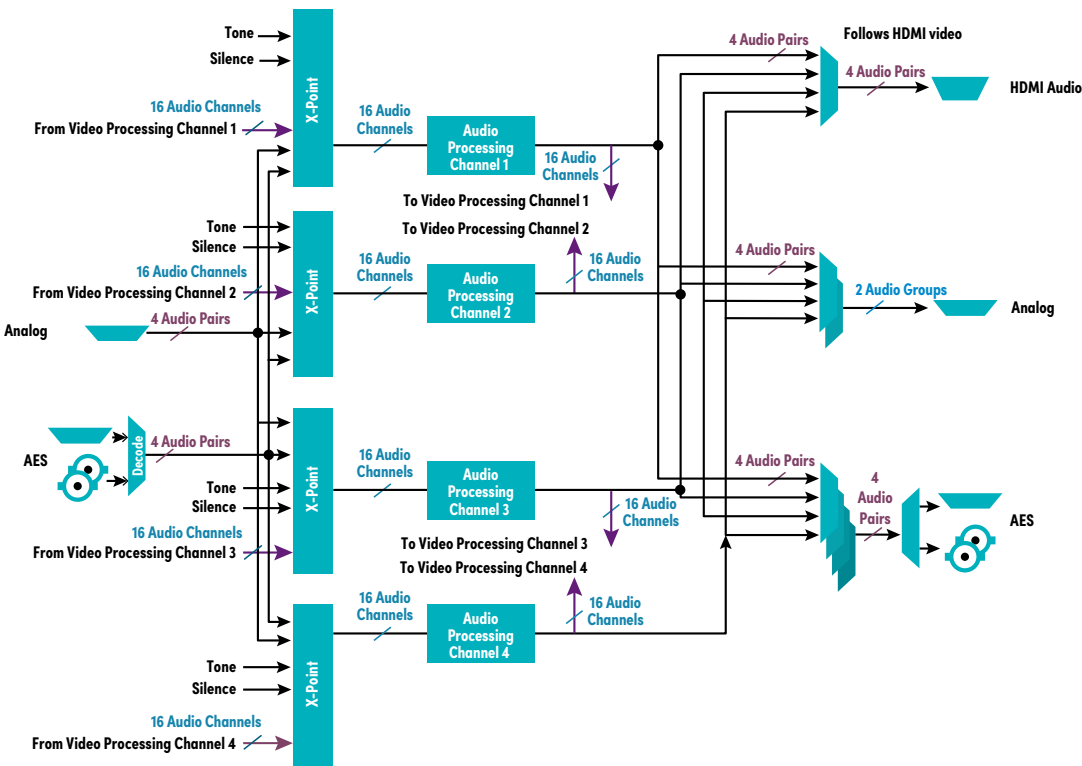

LC2000/4000 Rear Panel

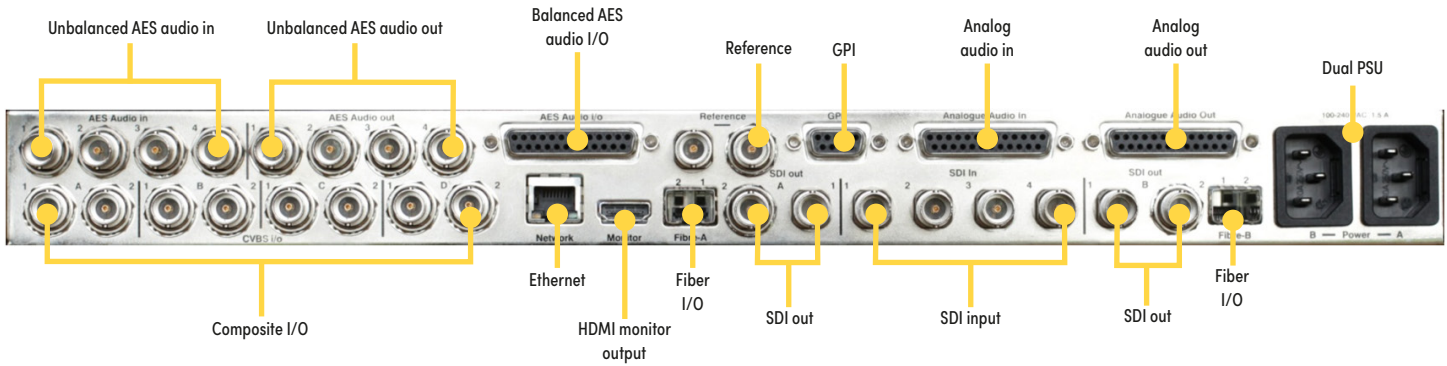

Specifications

Signal Inputs

Serial digital 4x 75Ω SD/HD/3G serial digital with embedded audio

Input standards:

- 3 Gb/s SD-SDI, SMPTE ST 425 level A, level B
- 1.5 Gb/s HD-SDI SMPTE ST 292/SMPTE ST 299
- 270 Mb/s SD-SDI SMPTE ST 259

Composite PAL, NTSC, NTSC-J, PAL-M, PAL-N, N4.4, SECAM

12-bit ADCs

Analog component YC

Reference: 1x loop-through HDTV Tri-sync/SD Bi-sync (blackburst) SMPTE ST 240/SMPTE ST 274

Audio AES:

- 4x balanced AES inputs – via 25-way D-type
- 4x unbalanced AES inputs – via 4x BNC

Audio analog: 4x stereo analog inputs via 25-way D-type

Signal Outputs

Serial digital 4x 75Ω SD/HD/3G serial digital with embedded audio

Output standards:

- 1.5 Gb/s HD-SDI SMPTE ST 292/SMPTE ST 299
- 270 Mb/s SD-SDI SMPTE ST 259

Composite PAL, NTSC, NTSC-J, PAL-M, PAL-N

12-bit DACs

Analog component YC

Audio AES:

- 4x balanced AES outputs – via 25-way D-type
- 4x unbalanced AES outputs – via 4x BNC

Audio analog: 2x stereo analog outputs via 25-way D-type

Input Standards

(auto detect) 525, 625

720 50/59.94/60p

1080 50/59.94/60i

1080 50/59.94/60p (Levels A and B)

720/1080 23.98/24/25/29/30p

1080 23.98/24/25/29.97/30PsF, with film detection and processing

2160 23/24/25/29/30p (6G-SDI single-link, Level B dual stream)

2160 50/59.94/60p (12G-SDI single link Level A)

Output Standards

525, 625

720 50/59.94/60p

1080 50/59.94/60i

1080 50/59.94/60p (Levels A and B)

720/1080 23.98/24/25/29/30p

1080 23.98/24/25/29.97/30PsF, with film detection and processing

Conversion Functions

Modes:

SD/HD/3G up/down/crossconversion at the same frame rate

Frame synchronizer

Manual or Automatic ARC

AFD (SMPTE ST 2016), VI (RP186), WSS (L23)

SD input format: Normal 4:3, Anamorphic 16:9, Letterbox 14:9, Letterbox 16:9

SD output format: Normal 4:3, Anamorphic 16:9, Letterbox 14:9, Letterbox 16:9

Auto zoom: On/Off

Manual zoom: Zoom ±20%

Safe area marker: Off, 16:9, 4:3

Manual controls: size, aspect, pan, tilt

Wide range of ARC presets including 702 sample line mode

Audio Functions

Analog Audio:

- Four pairs of analog inputs are individually available to any or all processing channels
- Two groups (2 pairs) of analog output are separately assignable to any processing channel
- Headroom +24 dBu; balanced connection

AES Audio:

- Four AES audio inputs are individually available to any or all processing channels
- Four AES audio outputs (48 kHz) are separately assignable to any processing channel
- AES input is auto-detected as PCM (32-96 kHz) or non-PCM (48 kHz locked to relevant video input)

Embedded Audio:

- Each processing channel includes 16-channel embedded audio processing
- PCM audio processing includes channel level gain and delay compensation, as well as channel level routing/shuffle with audio phase inversion
- Non-PCM processing features pair level routing and delay compensation

Specifications

Metadata

Closed caption CEA608 <> CEA708

Timecode conversions

WST/SMPTE RDD08/SMPTE ST 2031 conversion

Enhancement

Advanced Horizontal Enhancement:

- Frequency band selection (Low, Med, High)
- 4 preset enhancement levels (Low, Med, High, Super)
- Custom H Gain and H Noise rejection levels

Advanced Vertical Enhancement:

- Frequency band selection (Low, Med, High)
- 5 preset enhancement levels (Soft 2, Soft 1, Normal, Sharp 1, Sharp 2)

Horizontal Aperture:

- 5 preset H sharpness levels (Low 2, Low 1, Normal, High 1, High 2)
- 5 preset H detail levels (Soft 2, Soft 1, Normal, Sharp 1, Sharp 2)

Noise reduction: spatial, recursive

Y/C alignment: corrects for up-stream lum chroma displacement

System

Pattern Off, Black, Ramp, Bars

Proc amp:

Black Level: +100 to -100 mV (0) in 0.8 mV steps

Contrast: -6 dB to +6 dB (0) in 0.2 dB steps

Saturation: -6 dB to +6 dB (0) in 0.2 dB steps

Y Gamma: 0.4 to 1.7 (1) in 0.1 steps

Freeze: On/Off

Genlock: Reference lock, Input lock (same format), Follow input (same frame rate), Free run

Memories: 16 user memories

Legalizer

EDH support

Communications

Remote control via GV Orbit and SNMP

Power (Primary and Secondary)

Input voltage range: 100 – 240 VAC, 50/60 Hz 1.5A (max.) via three-pin IEC power socket

Mechanical

Temperature range: 0 to 45° C (32° to 113° F) operating

Cooling: Internal fan, side venting

Weight: Approximately 4.25 kg (9.4 lbs.)

Case type: 1 RU, rack mounting

Dimensions: 44 x 430 x 400 mm (1.7 x 16.9 x 15.7 in.) (HxWxD)

Headphones socket with volume control

GPIO: 8 available

Throughput Delay

Video processing delay:

– **Field = 16.7 or 20 ms**

– **Frame = 33.3 or 40 ms**

With scaling active in same frame rate:

– Ref lock/Free run – Between 3 and 5 fields + ~200 μ s

– Input lock (SDI) – 3 fields + 1ms

With same standard in & out and sync mode = Enabled:

– Ref lock/Free run – Between ~200 μ s and 1 frame + ~200 μ s

– Input lock (SDI) – ~1 ms

Frame-rate conversion: Any lock mode – 110 ms typical

Audio processing delay: (Audio delay = 0 ms)

With scaling active in same frame rate:

– Ref lock/free run – 1.5 frames

– Input lock – 1 frame + 1 ms

With same standard in & out and sync mode = Enabled:

– Ref lock/free run – 0.5 frames

– Input lock – ~3 ms

Frame-rate conversion: Any lock mode – 110 ms typical

Ordering

6112110

SV2000-CT2 Dual channel video & audio processing unit, including format conversion, frame synchronization, ARC control, noise reduction, side-bar keying, logo insertion, CC, WST and timecode handling, picture enhancement tools, 16-channel audio processing including gain, delay & shuffling. SDI (BNC or fiber), CVBS, GPI, AES and analog audio I/O. HDMI monitor output & dual PSUs.

6114110

SV4000-CT2 Quad channel video & audio processing unit, including format conversion, frame synchronization, ARC control, noise reduction, side-bar keying, logo insertion, CC, WST and timecode handling, picture enhancement tools, 16-channel audio processing including gain, delay & shuffling. SDI (BNC or fiber), CVBS for 2 channels, GPI, AES and analog audio I/O. HDMI monitor output & dual PSUs.

Fiber SFP Options for Fiber – A&B

FC1-13TR

Transceiver 1310 nm/Rx

FC1-13T1

Single 1310 nm Tx

FC1-13T2

Dual 1310 nm Tx

FC1-R1

Single Rx

FC1-R2

Dual Rx

FC1-HDBT2

HD-BNC Dual Tx

FC1-HDBR2

HD-BNC Dual Rx

Note: Fiber SFP type must be ordered in addition to the unit.

This product may be protected by one or more patents. For further information, please visit: www.grassvalley.com/patents

DS-PUB-3-1063B-EN

Grass Valley®, GV®, GV Grass Valley®, and the Grass Valley logo are trademarks or registered trademarks of Grass Valley USA, LLC, or its affiliated companies in the United States and other jurisdictions. Grass Valley products listed above are trademarks or registered trademarks of Grass Valley USA, LLC or its affiliated companies, and other parties may also have trademark rights in other terms used herein. Copyright © 2024 Grass Valley Canada. All rights reserved. Specifications subject to change without notice.

www.grassvalley.com Join the Conversation at GrassValleyLive on [Facebook](#), [X](#), [YouTube](#) and Grass Valley on [LinkedIn](#)